

# Part #: PJDI106

For serial number >05370953

## D07RE125-3GPM

Ask us about our Maintenance Manuals available on CD!

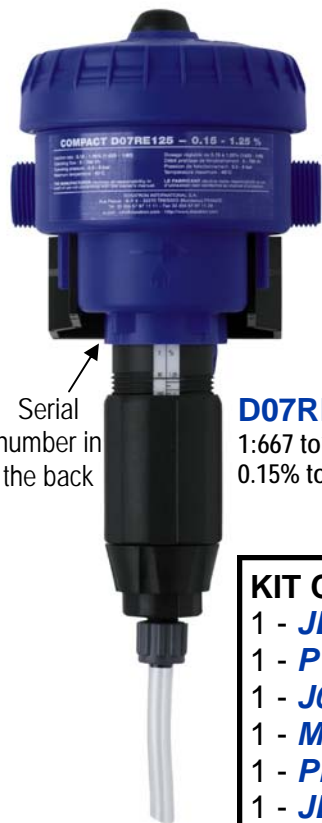

**D07RE125**  
1:667 to 1:80  
0.15% to 1.25%



### KIT CONTENTS:

- 1 - **JDI106** Plunger seal
- 1 - **P169** Check valve barb
- 1 - **J051** Check valve seal
- 1 - **MPDI122** Check valve assembly
- 1 - **PDI550** Injection sleeve key
- 1 - **JDI092** Injection stem o-ring
- 1 - **8J026** Injection sleeve o-ring

Let us remind you when it is time for maintenance!  
Register your unit at:  
[www.dosatronusa.com/pm](http://www.dosatronusa.com/pm)  
for automatic notifications.



## D07RE125 Seal Kit Instructions (Serial number higher than 05370953)

(Blue part number denotes it is part of the kit)

1. Unscrew suction hose nut (P153) and remove suction hose.
2. Unscrew and remove injection stem assembly (CDDI067).
3. Unscrew the check valve barb (P169), remove the check valve seal (**J051**), unscrew the conical nut (P168), remove the anti-lock ring (P189) and remove check valve assembly (**MPDI122**) from the stem.
4. Unscrew the adjusting nut (PDI549). With the help of a small flat head screwdriver remove the plastic injection sleeve key (**PDI550**) located inside the lower part of the injection sleeve (PDI538). Remove the injection stem (PDI534) from the bottom of the injection sleeve (PDI538). Replace the injection stem o-ring (**JDI092**) and injection sleeve o-ring (**8J026**).
5. Insert injection stem (PDI534) into the bottom part of the injection sleeve (PDI538). Make sure that the long groove in the injection stem aligns with the hole in the lower part of the injection sleeve. With the help of a small flat head screwdriver install the new plastic injection sleeve key (**PDI550**) all the way into the injection sleeve (PDI538). Thread the adjusting nut (PDI549) onto the injection sleeve (PDI538) until reaches the top of the scale.
6. Reinstall the anti-lock ring (P189) and the conical nut (P168). Insert new check valve assembly (**MPDI122**) into the injection stem, the cone should point out. Position the check valve seal (**J051**) into the new check valve barb (**P169**) with the groove facing up. Thread the new check valve barb.
7. Replace the plunger seal (**JDI106**).
8. Thread injection stem assembly (CDDI067) into the body.
9. Slide suction hose nut (P153) onto the suction hose, reattached suction hose onto check valve barb and tighten suction hose nut (P153).

**\*\*DO NOT FORGET TO RESET YOUR INJECTION RATE TO THE PROPER RATIO\*\***

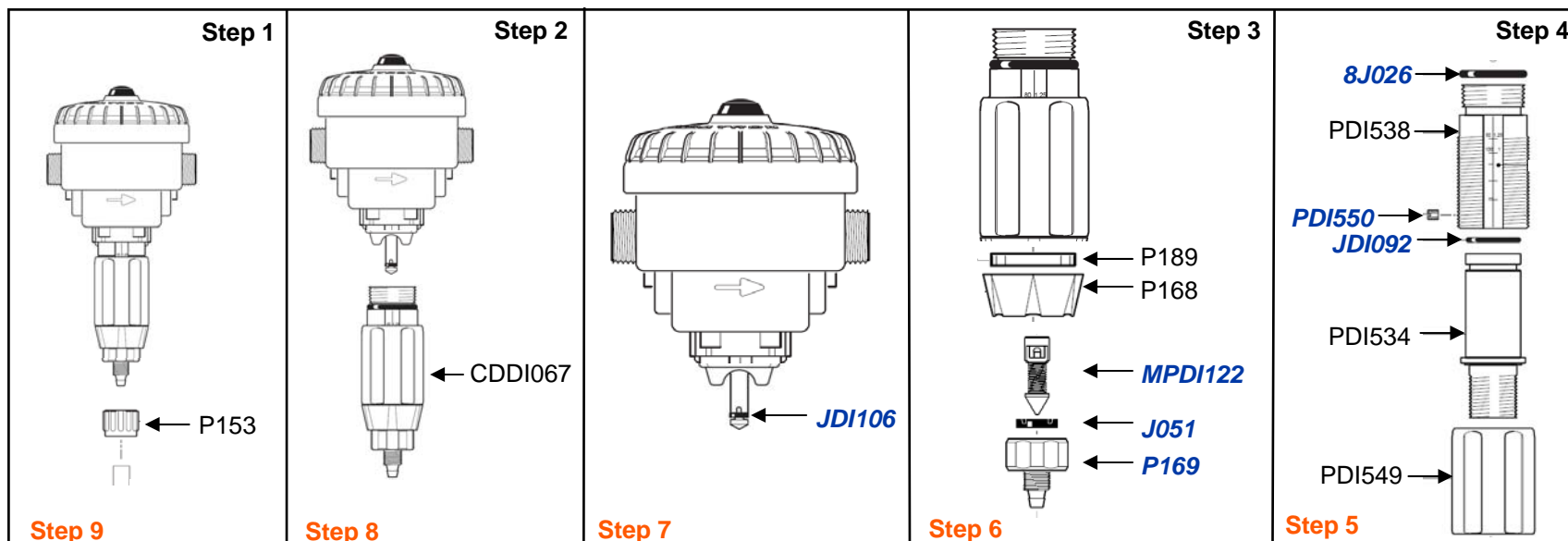

NOTE: If your Compact serial number is less than 05370952, please contact us to receive the correct plunger seal JDI094 instead of JDI106.