



**DOSATRON®**

WATER POWERED DOSING TECHNOLOGY

---

# SCHEMATICS

## Dosatron Liquid Dispenser **Model # DI210 – 11 GPM**

1:50 – 1:10

7 – 57 PSI

$\frac{3}{4}$ " NPT Connection

### **Suggested Installation:**

200 mesh/80 micron water filter prior to unit

One-way check valve downstream from unit for water hammer protection

### **Suggested Maintenance Interval:**

Replace injection seals every 12 months

---

### **DOSATRON SALES & SERVICE - NORTH & CENTRAL AMERICA**

Dosatron International, Inc.

Phone: 727-443-5404 Service: (800) 523-8499

Fax: 727-447-0591

[www.dosatronUSA.com](http://www.dosatronUSA.com)

**DI210**  
11/03

11 GPM - 1:50 - 1:10  
7 - 57 psi

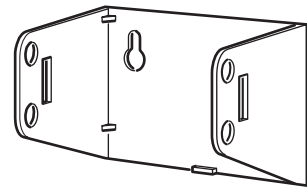
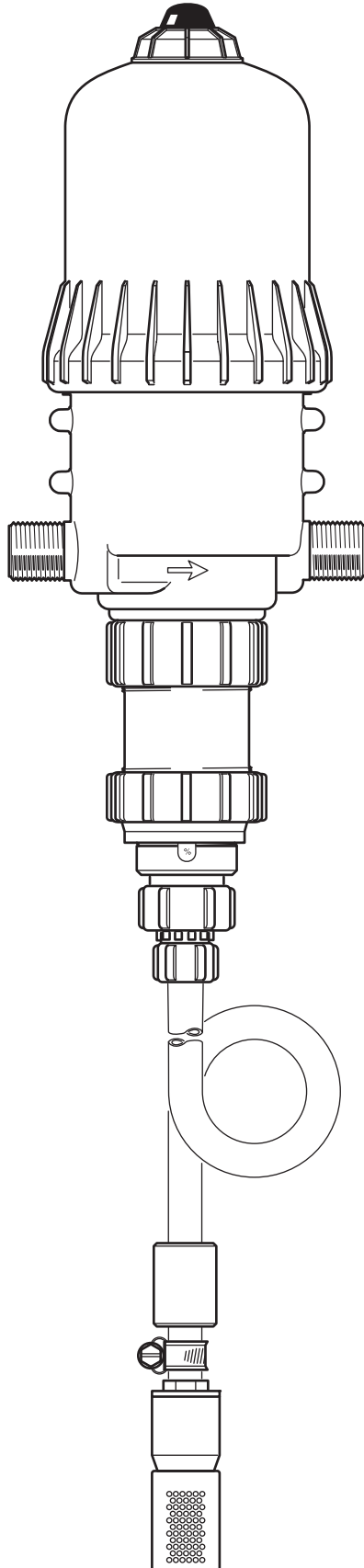

**DI210**  
11/03

11 GPM - 1:50 - 1:10  
7 - 57 psi

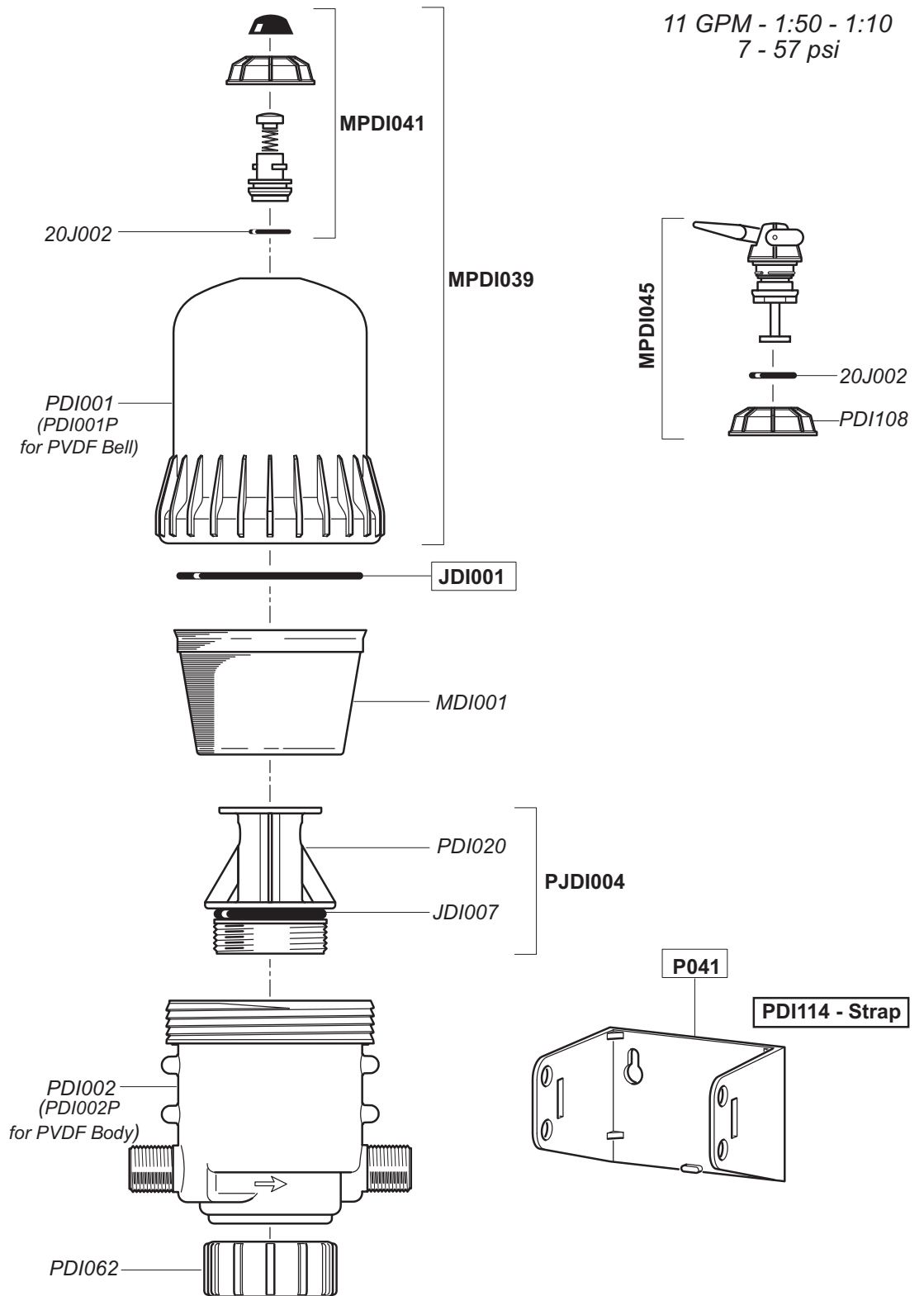

**DI210**  
11/03

11 GPM - 1:50 - 1:10  
7 - 57 psi

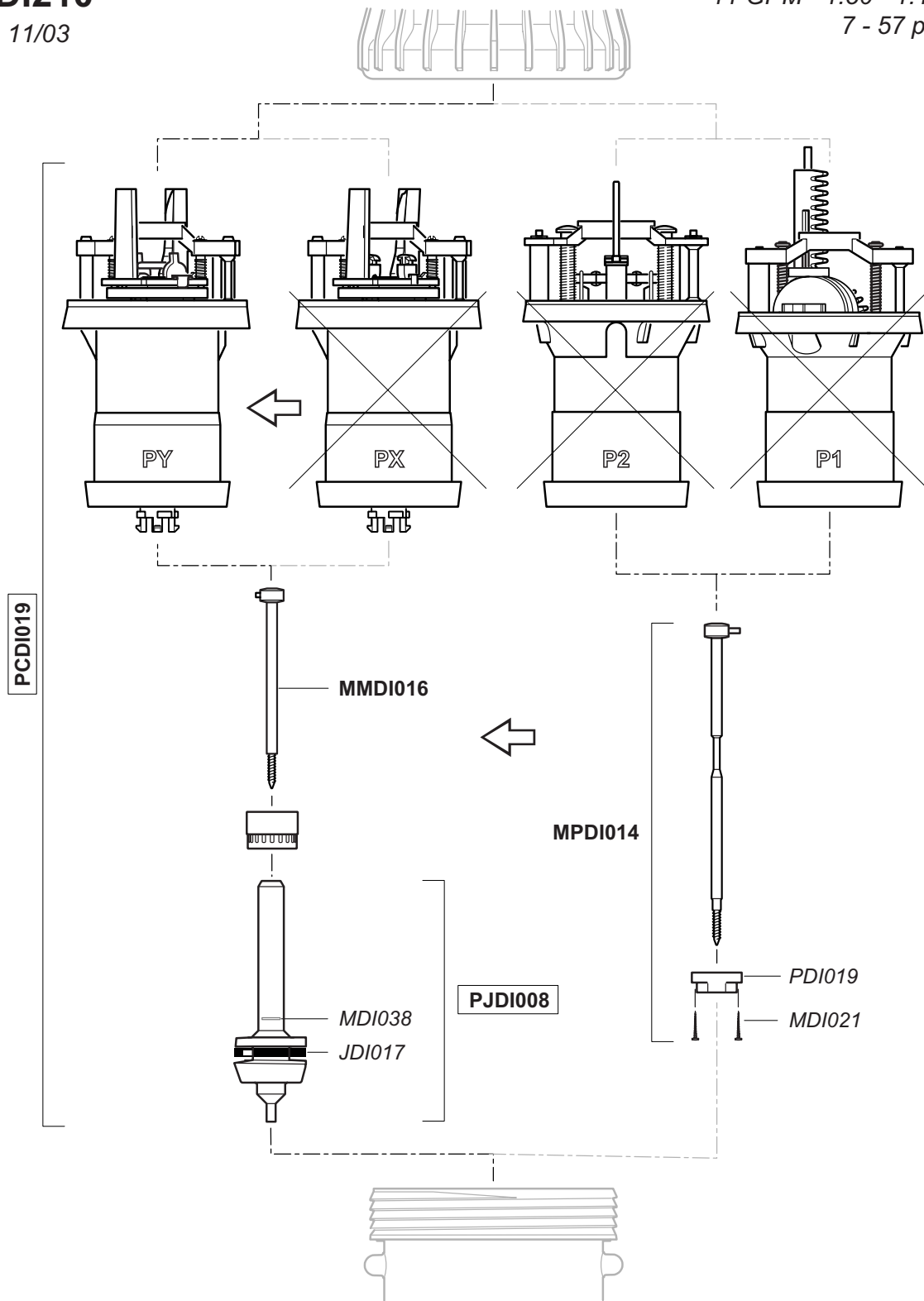

**DI210**  
11/03

11 GPM - 1:50 - 1:10  
7 - 57 psi

**PX**

**PY**

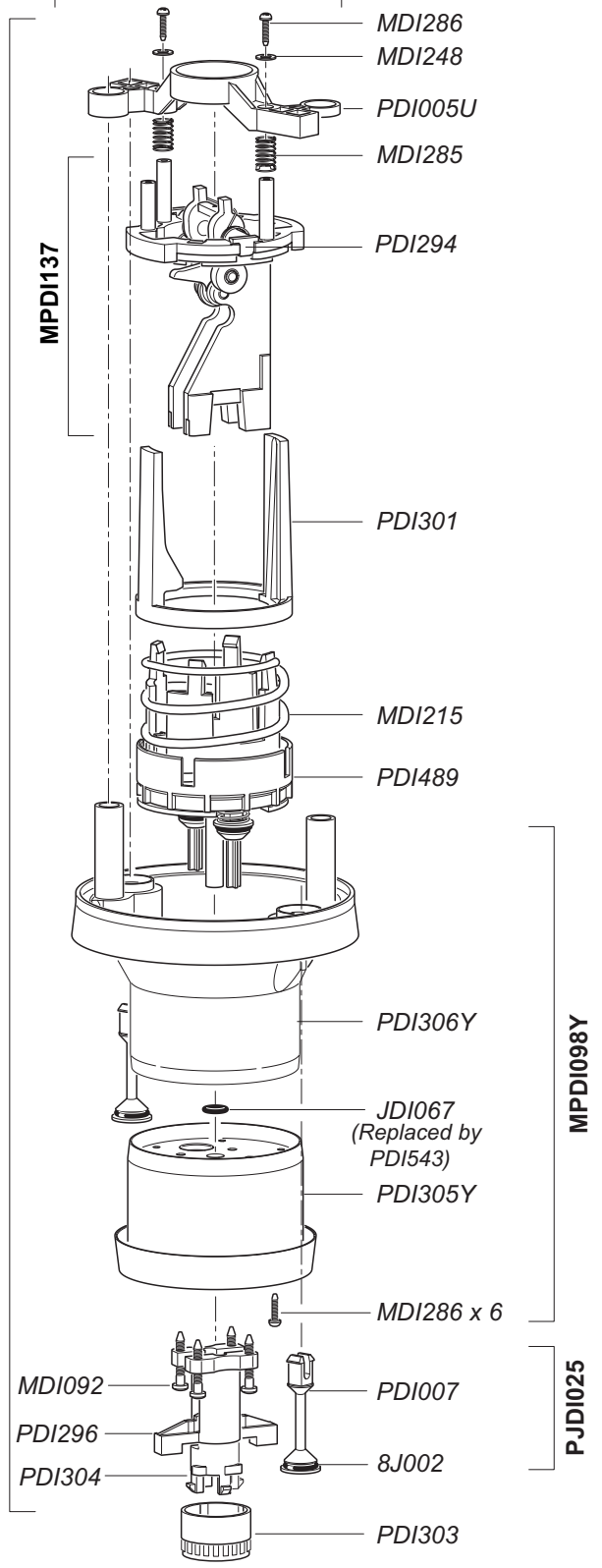
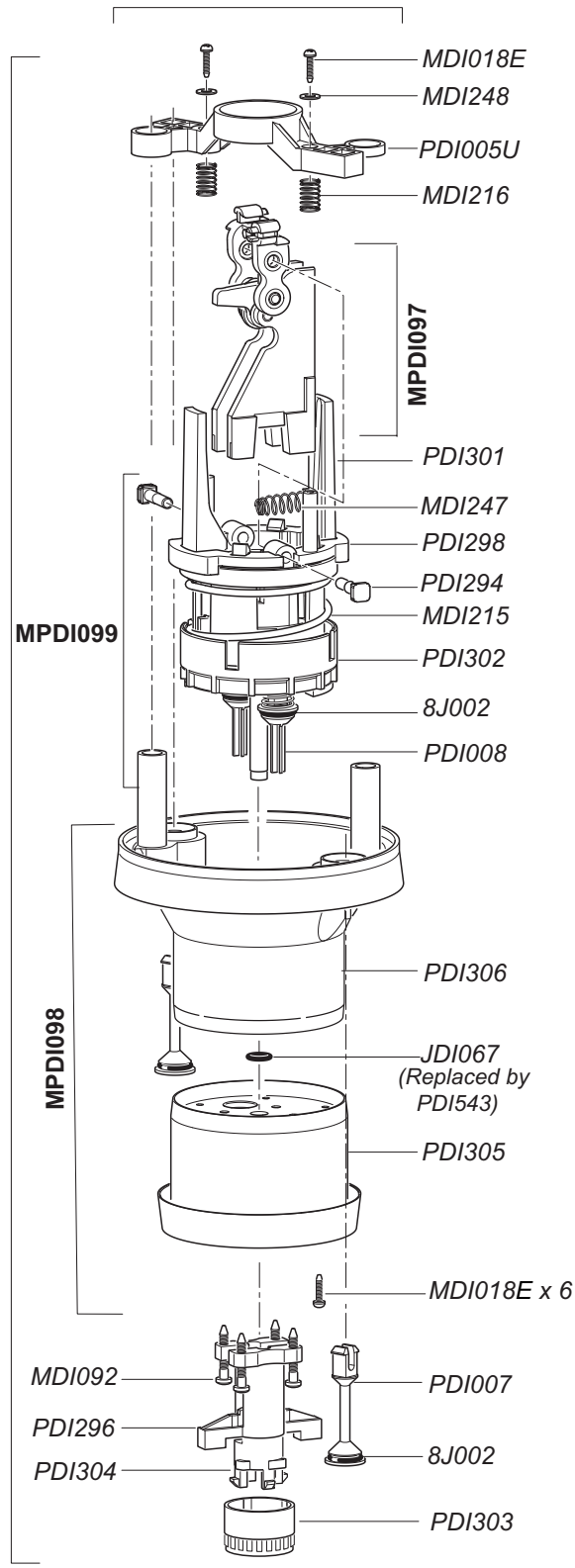

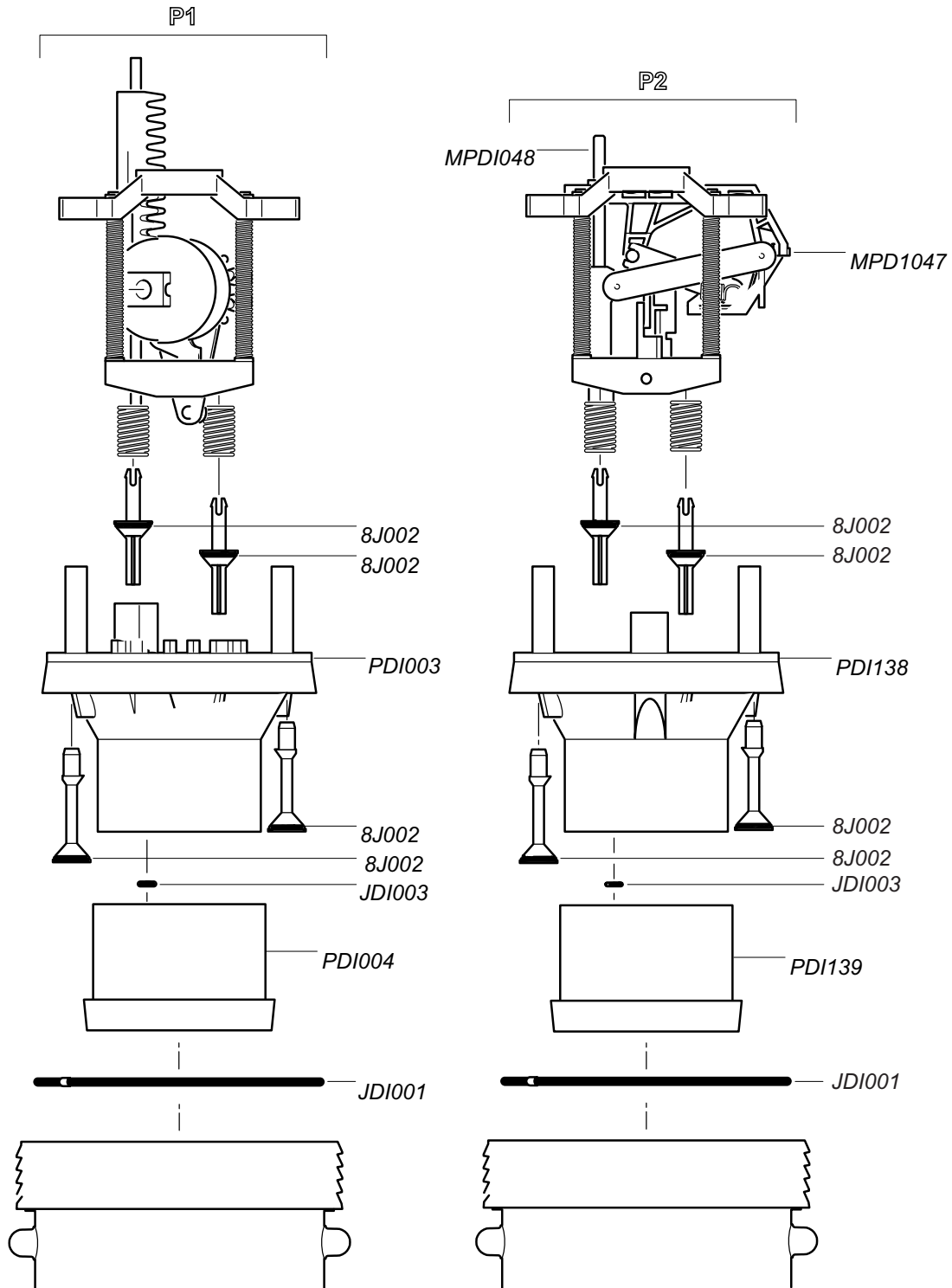

**DI210**  
11/03

11 GPM - 1:50 - 1:10  
7 - 57 psi

CDDI054 1/2" (Plunger not included)  
CDDI054V 3/4"

CDDI005 3/4"

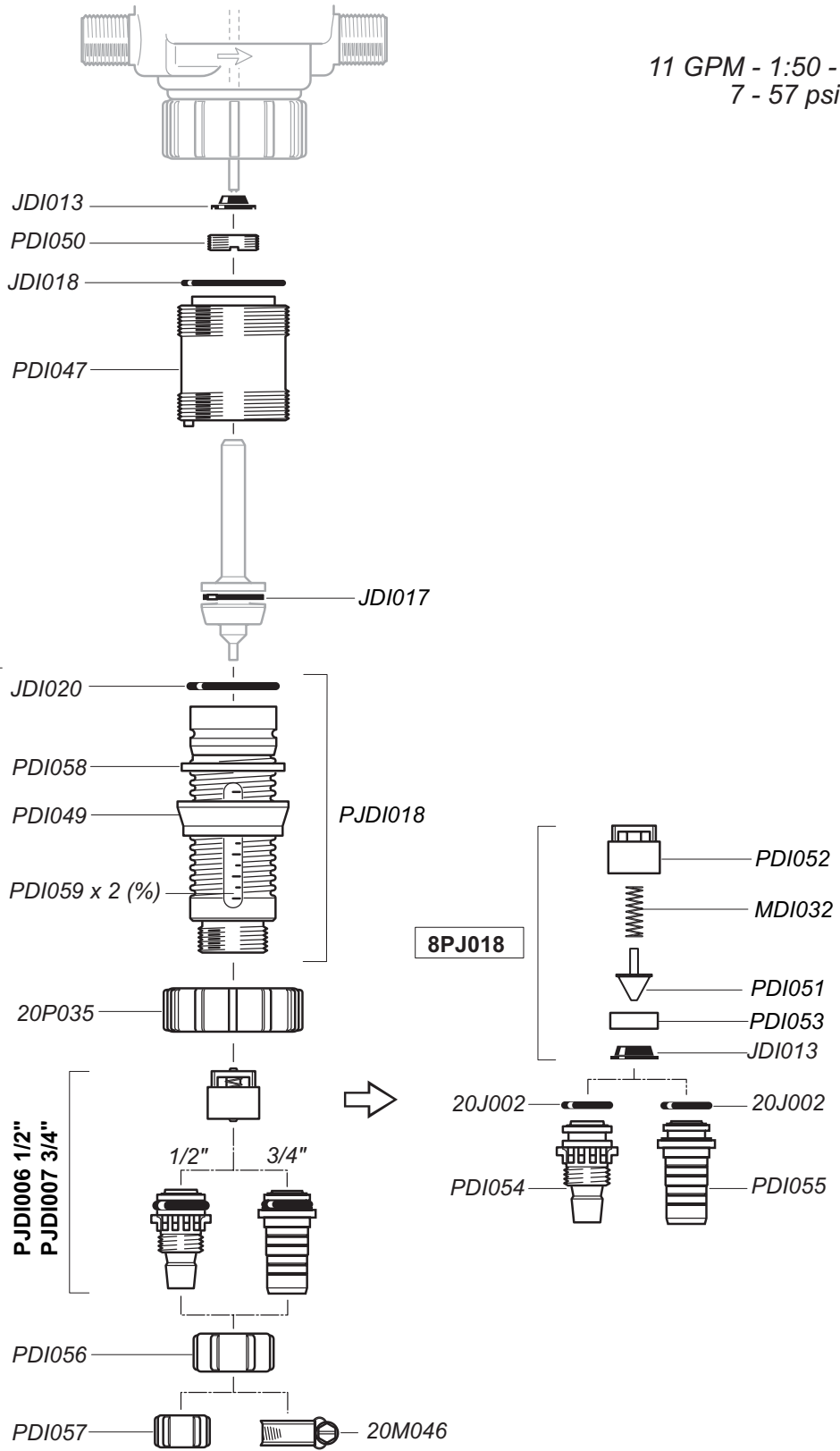

**DI210**  
11/03

11 GPM - 1:50 - 1:10  
7 - 57 psi

**Option "V"**

