



DOSATRON®

WATER POWERED DOSING TECHNOLOGY

SCHEMATICS

Dosatron Liquid Dispenser **Model # D400RE – 7 GPM**

1:200 – 1:25

7 – 70 PSI

Suggested Installation:

200 mesh/80 micron water filter prior to unit

One-way check valve downstream from unit for water hammer protection

Suggested Maintenance Interval:

Replace injection seals every 12 months

DOSATRON SALES & SERVICE - NORTH & CENTRAL AMERICA

Dosatron International, Inc.

Phone: 727-443-5404 Service: (800) 523-8499

Fax: 727-447-0591

www.dosatronUSA.com

D400RE
11/03

7 GPM - 1:200 - 1:25
7 - 70 psi

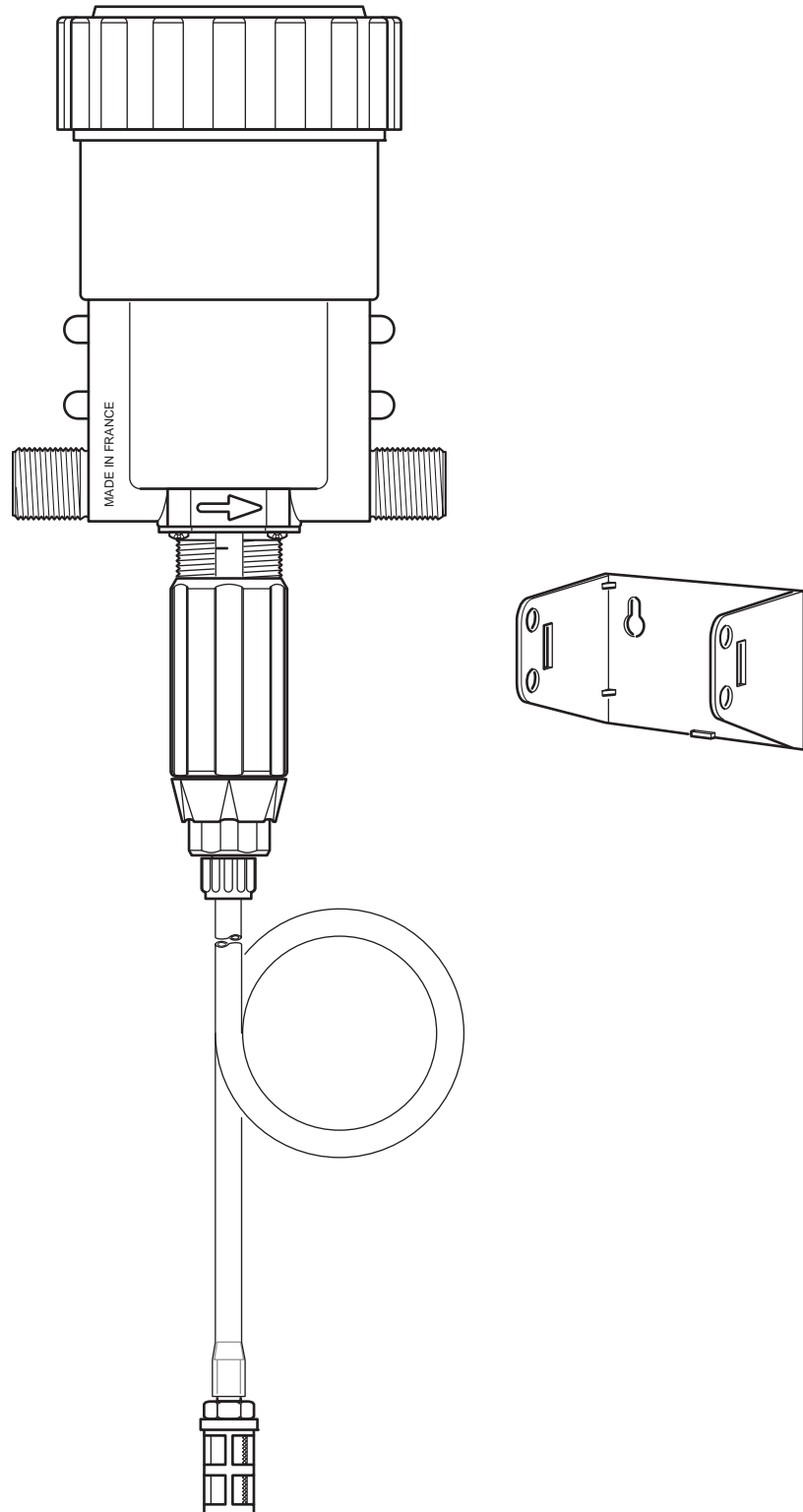

D400RE
11/03

7 GPM - 1:200 - 1:25
7 - 70 psi

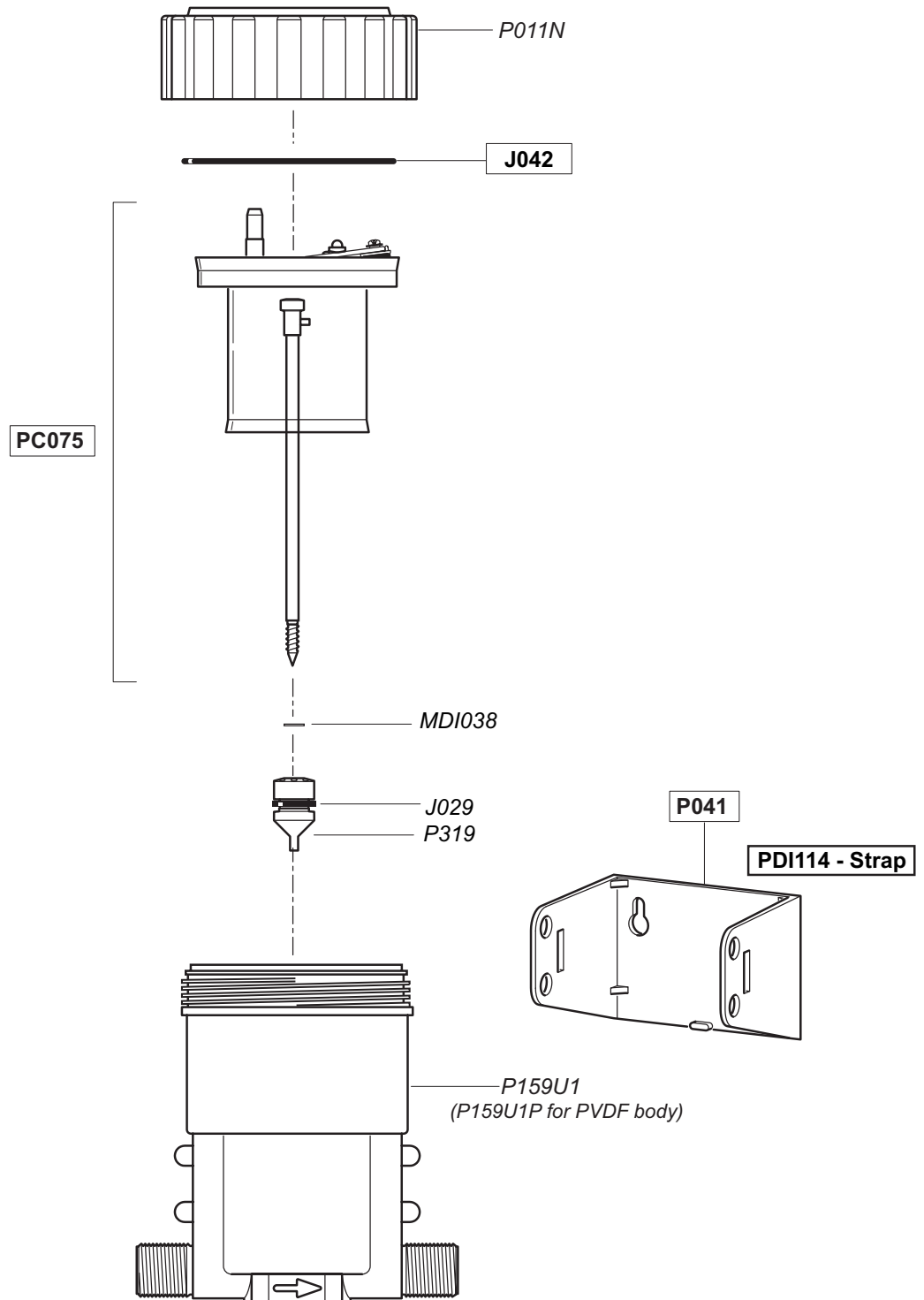

D400RE

11/03

7 GPM - 1:200 - 1:25
7 - 70 psi

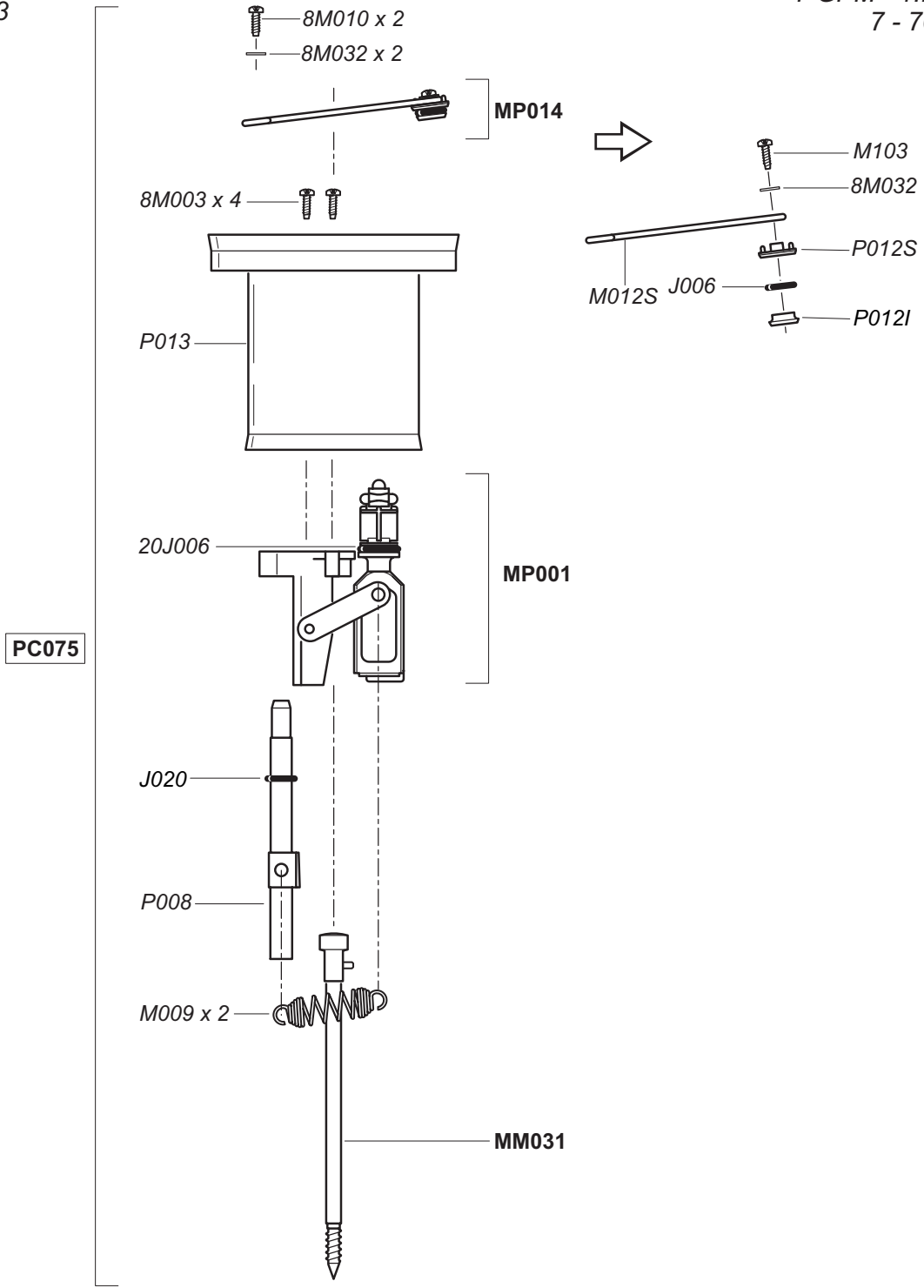

D400RE
11/03

7 GPM - 1:200 - 1:25
7 - 70 psi

CD064
CD064V

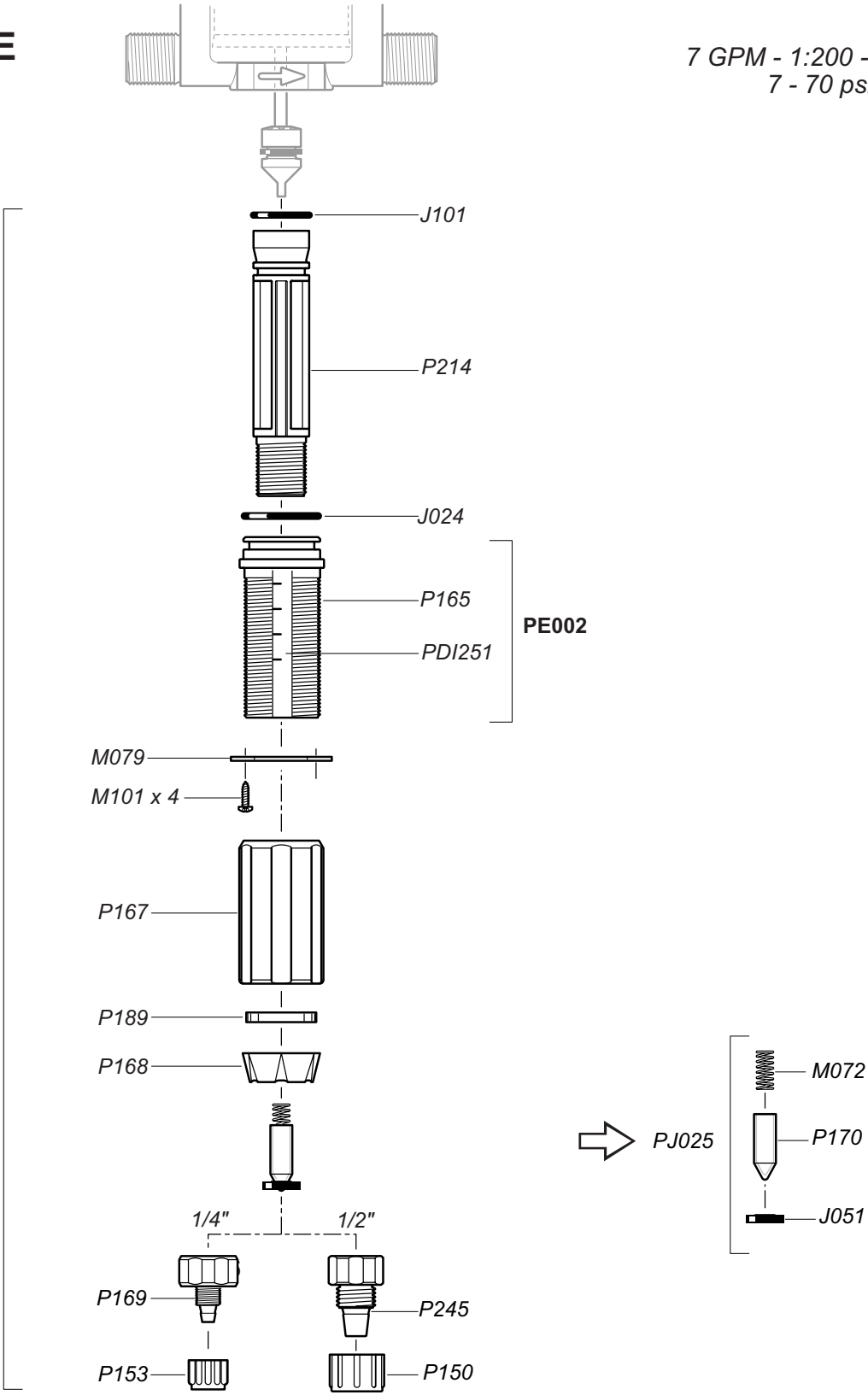

D400RE

11/03

7 GPM - 1:200 - 1:25
7 - 70 psi

