



**DOSATRON®**

*WATER POWERED DOSING TECHNOLOGY*

---

# SCHEMATICS

## Dosatron Liquid Dispenser **Model # D25RE5 – 11 GPM**

1:100 – 1:20

4.3 – 85 PSI

$\frac{3}{4}$ " NPT connection

### **Suggested Installation:**

200 mesh/80 micron water filter prior to unit

One-way check valve downstream from unit for water hammer protection

### **Suggested Maintenance Interval:**

Replace injection seals every 12 months

---

### **DOSATRON SALES & SERVICE - NORTH & CENTRAL AMERICA**

Dosatron International, Inc.

Phone: 727-443-5404 Service: (800) 523-8499

Fax: 727-447-0591

[www.dosatronUSA.com](http://www.dosatronUSA.com)

**D25RE5**  
11/03

11 GPM - 1:100 - 1:20  
4.3 - 85 psi

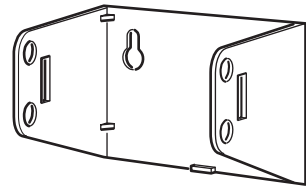
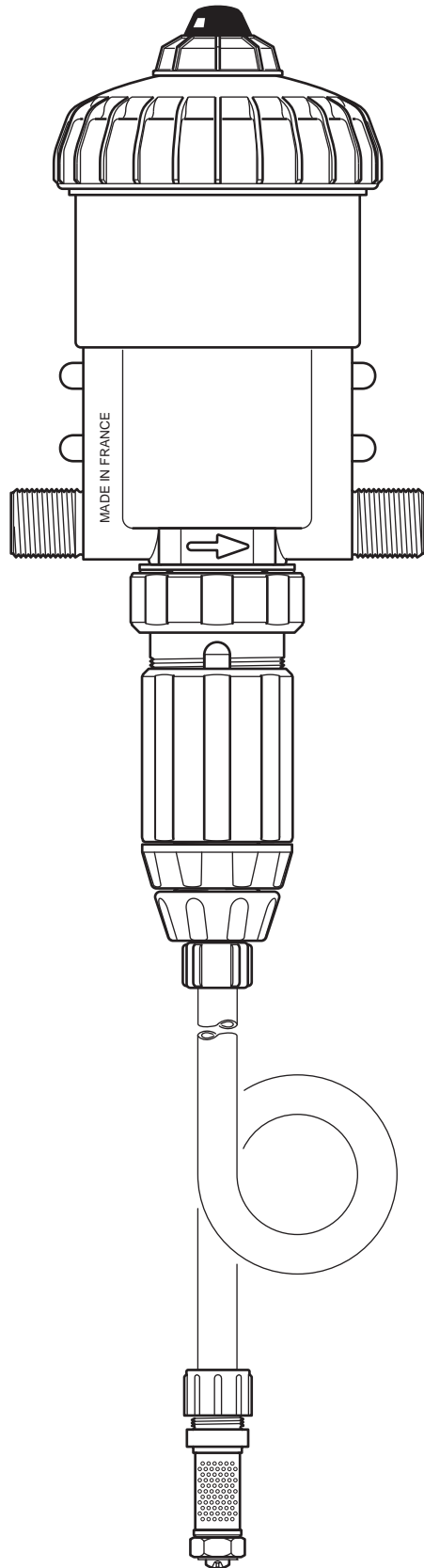

# D25RE5

11/03

11 GPM - 1:100 - 1:20  
4.3 - 85 psi

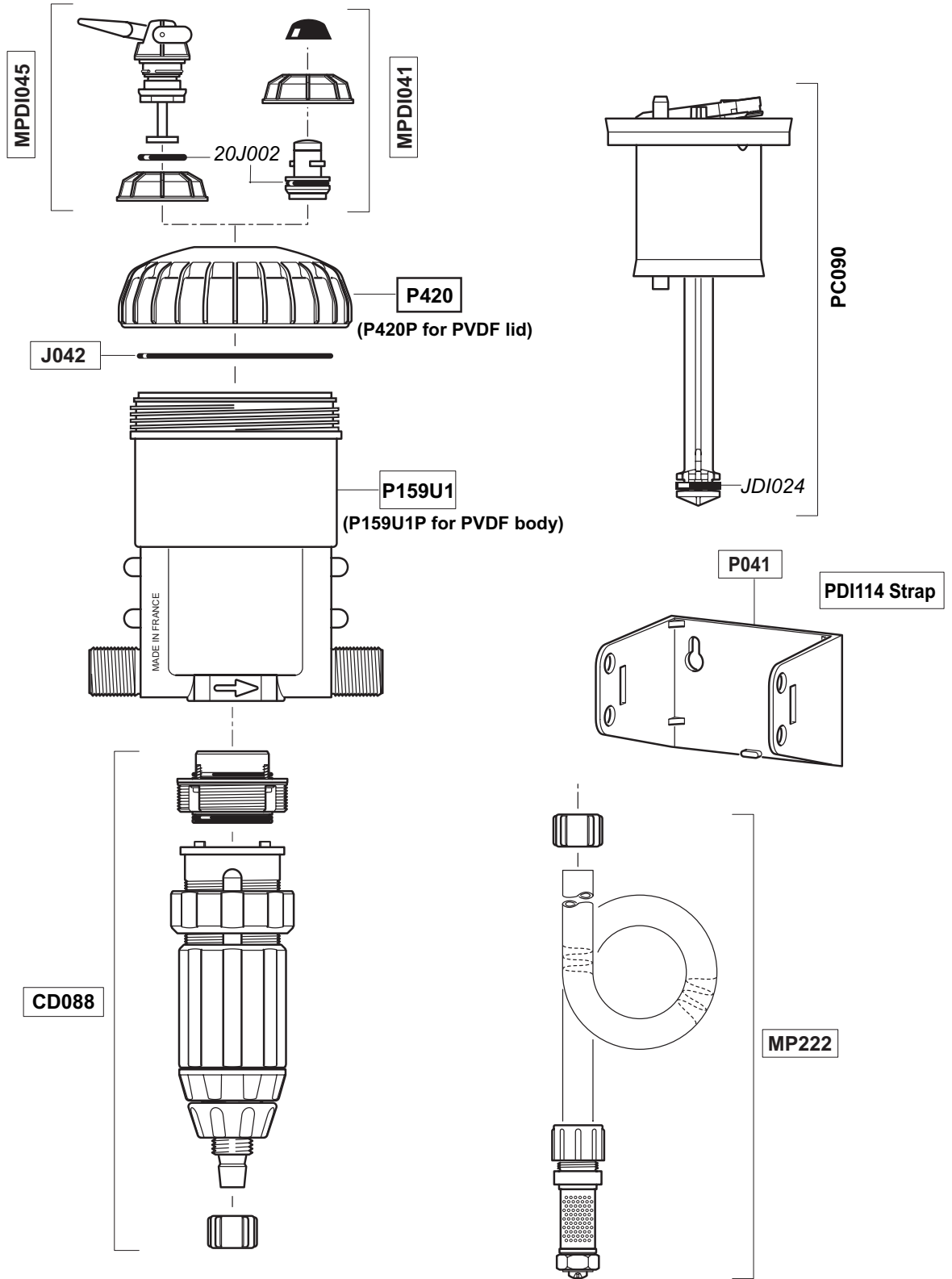

# D25RE5

11/03

11 GPM - 1:100 - 1:20  
4.3 - 85 psi

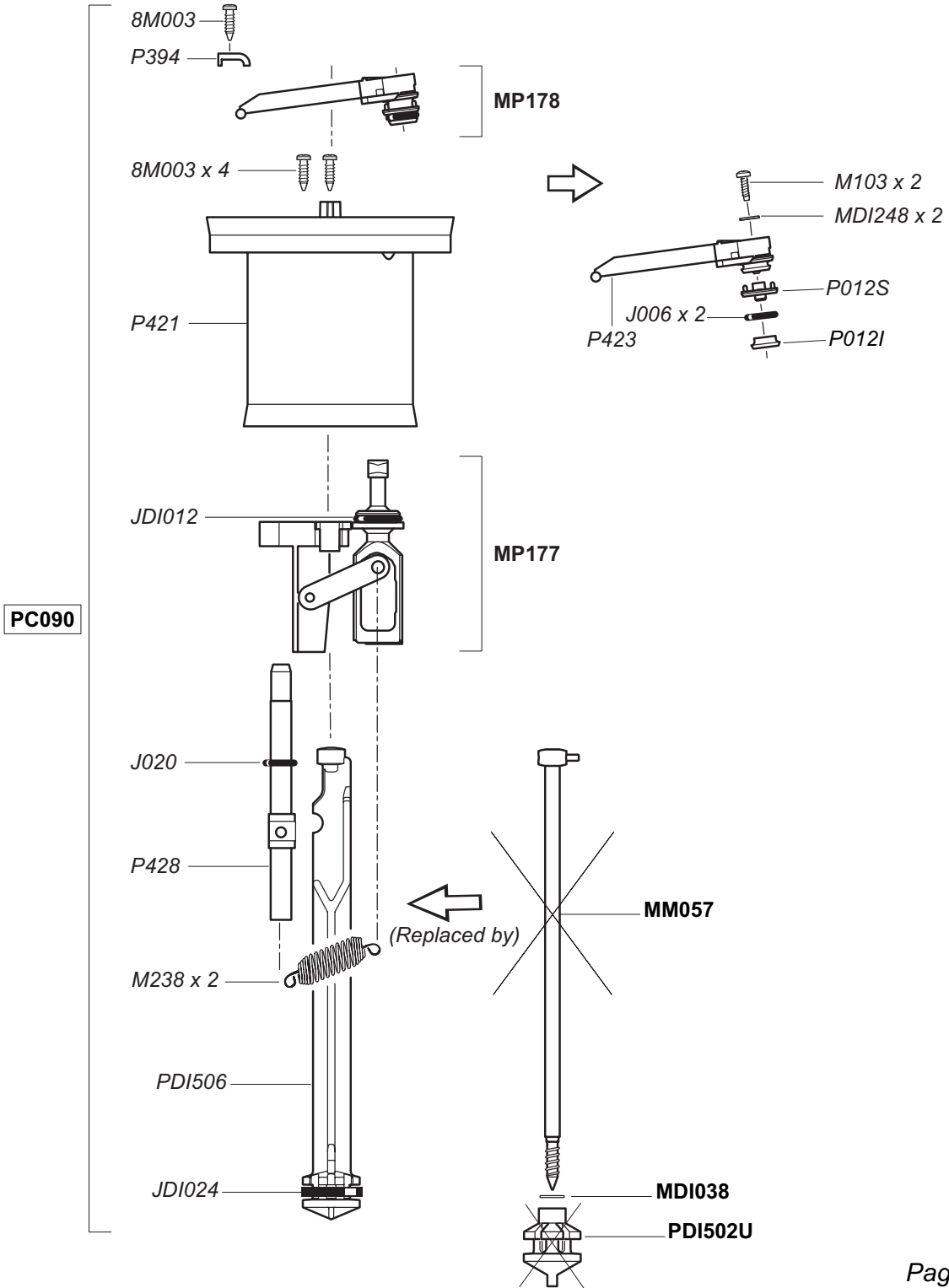

# D25RE5

11/03

11 GPM - 1:100 - 1:20  
4.3 - 85 psi

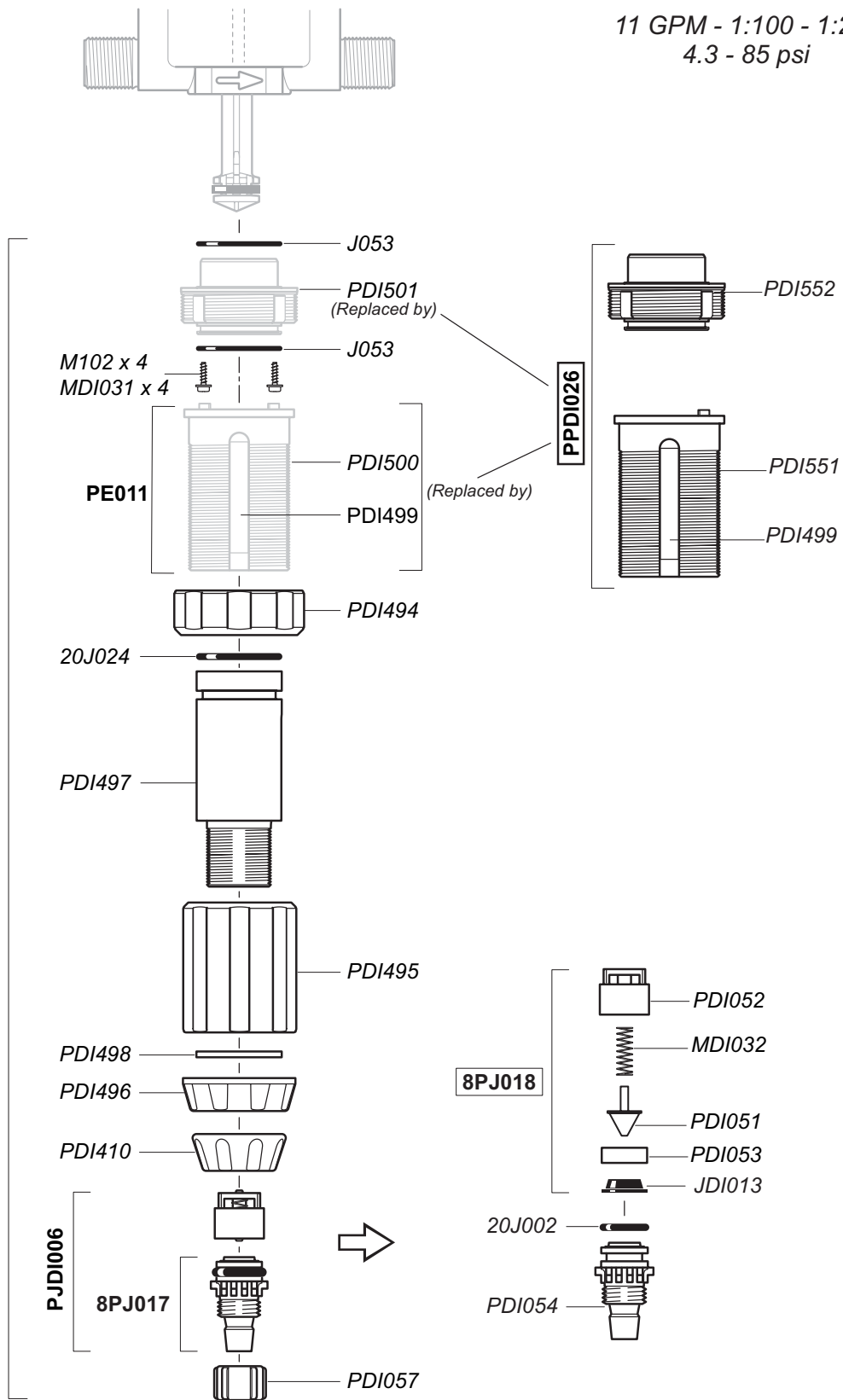

**D25RE5**  
11/03

11 GPM - 1:100 - 1:20  
4.3 - 85 psi

