



DOSATRON®

WATER POWERED DOSING TECHNOLOGY

EGG WASHING

Dosatron Chemical Dispensers

For all your egg sterilizing needs

Features	Benefits
Water-powered, non-electric	Reduced energy costs
Automatically compensates for changes in water flow and pressure	Offers consistent repeatable results
Simple to use and maintain	Less down time
Precise ratio adjuster	Controlled chemical costs with exact adjustability

Advantages

- On-demand dispensing eliminates waste
- Economical operation
- Simple to use and maintain



IDEAL FOR DISPENSING:

- Hydrogen Peroxide
- Chlorine
- Peracetic Acid

800-523-8499
www.dosatronusa.com

Unit Operation

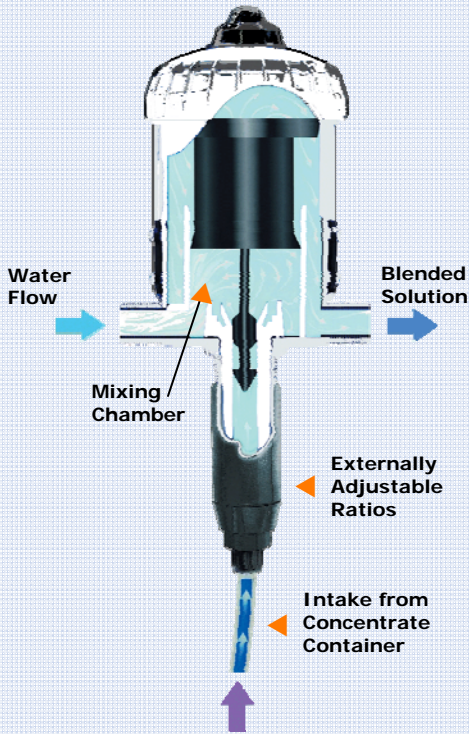

Bypass Installation

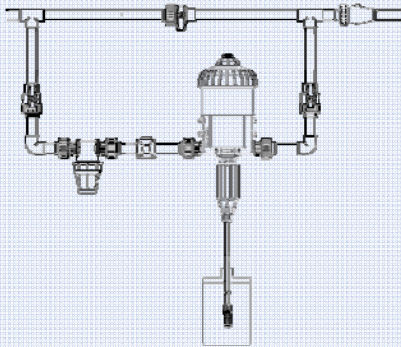

To order or for information call 800-523-8499

Not sure what unit fits your needs? Give us a call for unit recommendations.

Customer Service

At Dosatron, we stand behind our units. Our world-class customer service team is always ready to assist you with service and support, for as long as you own your Dosatron.

Preventive Maintenance Program

Sign up at www.dosatronusa.com/pm.



Unit Specifications

STANDARD SANITIZERS

Model	Maximum Flow Rate	Dilution Range	Flow Range	Pressure Range
D25RE2PVDF VFPPII	11 GPM	1:500 to 1:50	0.05 to 11 GPM	4.3 to 85 PSI
D25RE1500 PVDFVFPPII	11 GPM	1:1500 to 1:500	0.05 to 11 GPM	4.3 to 85 PSI

CHLORINE

Model	Maximum Flow Rate	Dilution Range	Flow Range	Pressure Range
D14MZ2VFII	14 GPM	1:500 to 1:50	0.05 to 14 GPM	4.3 to 85 PSI
D11500PVDF VFPYPII	11 GPM	1:1500 to 1:500	0.05 to 11 GPM	4.3 to 85 PSI

PERACETIC ACID

Model	Maximum Flow Rate	Dilution Range	Flow Range	Pressure Range
D14MZ2VFII	14 GPM	1:500 to 1:50	0.05 to 14 GPM	4.3 to 85 PSI
D11500PVDF VFPYPIIK	11 GPM	1:1500 to 1:500	0.05 to 11 GPM	4.3 to 85 PSI
D45RE15 PVDFVFPPIIK	20 GPM	1:500 to 1:66	0.40 to 20 GPM	7 to 70 PSI
D45RE3000PV DFVFPPIIK	20 GPM	1:3000 to 1:1000	0.40 to 20 GPM	7 to 70 PSI

All units include: mounting bracket, suction tube, strainer and weight. Please review the basic installation drawing for recommended accessories.

MAXIMUM TEMPERATURE: 104 °F

Basic Installation

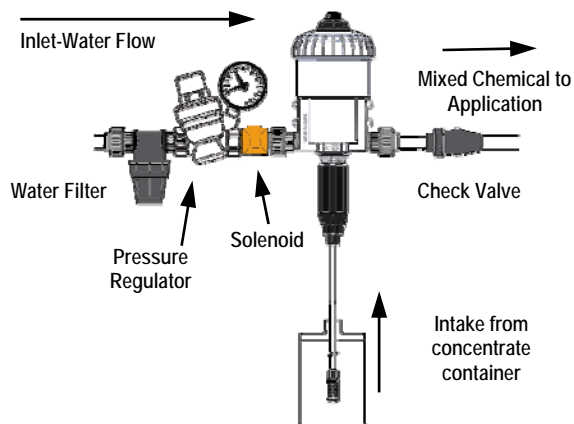

2090 Sunnysdale Blvd., Clearwater, FL 33765 USA • 727-443-5404
Toll Free: 800-523-8499 • Fax: 727-447-0591 • www.dosatronusa.com